

solar valves

Solar Control Kit

QIK15SCK-2

SOLAR CONTROL KIT

The new AVG Solar Control Valve is a cold water inlet combination valve for a roof mounted solar hot water heater. The valve assembly is installed in a convenient position for ease of operation.

This innovative cold water inlet combination incorporates an NRI/PRV, strainer and ECV all in one neat package designed with the installing plumber in mind.

The Solar Control Valve requires no thread sealant or tape to assemble and has 15mm compression inlet and outlet connections.

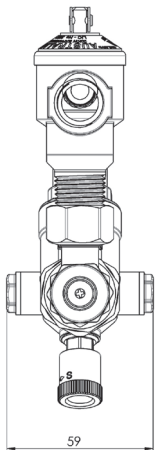
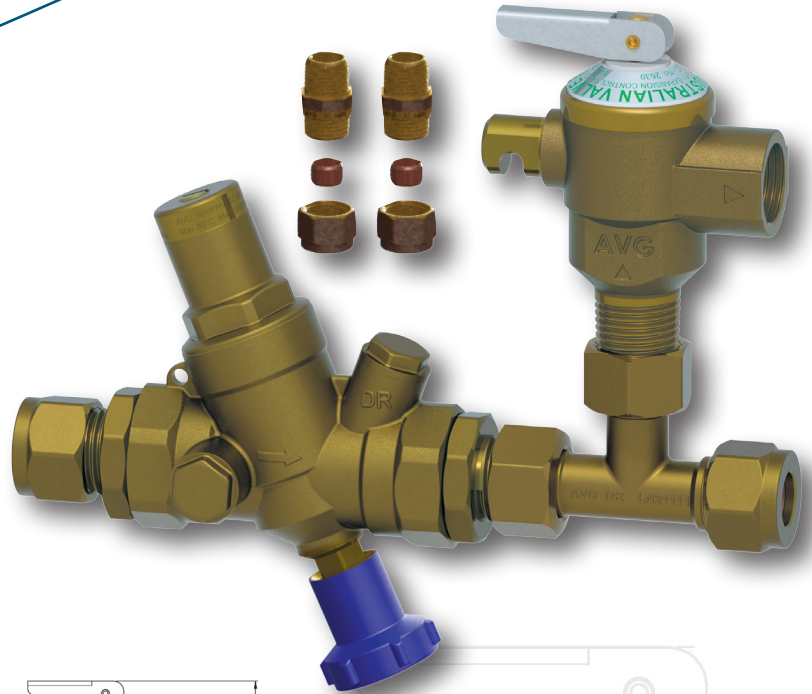

QIK15SCK-2 DIMENSIONS

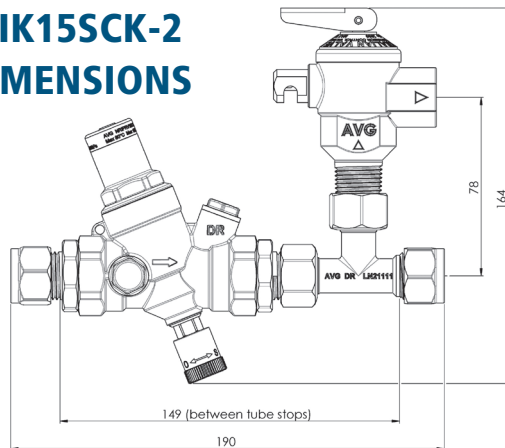

FEATURES

- Compact design
- Convenient isolation for service or repairs
- Adjustable pressure
- All directional ECV position
- Replaceable ECV
- Vertical or horizontal orientation
- High Performance TVA included

SPECIFICATIONS

Valve	DR brass
Line strainer	Stainless steel
Check valve cartridge.	NORYL
O rings	EPDM
End connections	15mm
Compression olives	Copper



Includes
TVA15CHP-i